

# Soft Starting of Induction Motors in Traditional Oil Mining Using Arduino Uno

Harrij Mukti K<sup>1</sup>, Rohmanita Duanaputri<sup>2\*</sup>, Rachmat Sutjipto<sup>3</sup>, Muhammad Fahmi Hakim<sup>4</sup>, Ahmad Hermawan<sup>5</sup>, Abdillah Toha Yusuf<sup>6</sup>, Rifqi Nanda Prayoga<sup>7</sup>

<sup>1,2\*,3,4,5,6,7</sup> Politeknik Negeri Malang, Surabaya, Indonesia



## ABSTRACT (9 pt)

### **Keywords:**

*Soft starting,  
Induction motor,  
Arduino Uno,  
Oil mining,  
Energy efficiency,  
Sustainability*

High energy consumption during the starting process of induction motors is a significant challenge in traditional oil mining operations. Starting current surges not only cause mechanical stress and instability of the power grid, but also result in substantial energy waste. The use of a soft starting method with Arduino Uno offers a potential solution to address these issues. A soft starting system was designed and tested using Arduino Uno as the control platform, aiming to provide a controlled and environmentally friendly approach to motor start-up. Tests were conducted under various loads to assess energy savings and sustainability improvements. Results showed that the method successfully reduced the initial current surge to approximately 150% of the rated current, compared to 500% in direct starting (DOL). The implementation of this system is a significant step towards a more environmentally friendly and energy-efficient oil extraction method, contributing to improved motor reliability, reduced energy consumption, and increased efficiency and sustainability in traditional oil mining practices.

---

## INTRODUCTION

Induction motors are crucial in traditional oil mining due to their cost-effectiveness, easy maintenance, and high reliability (Sen, 2021). However, they face a significant challenge during startup: a current surge up to seven times the nominal value, which can stress components, affect reliability, and increase energy consumption (Rashid, 2014).

To address this, efficient power regulation systems like soft starting have emerged. Soft starting allows gradual motor start, reducing initial current surges (Chapman, 2012). This method not only protects the motor and maintains electrical network stability but also contributes to energy efficiency and sustainability in industrial operations. Studies show soft starting can reduce start-up energy consumption by up to 30% compared to conventional methods (de Almeida et al., 2014).

The Arduino Uno microcontroller, known for its versatility and ease of use, has gained popularity in automation and control systems (Margolis et al., 2020). Its low cost and robustness make it suitable for harsh conditions in oil mining. Integrating Arduino Uno in soft starting systems for induction motors offers precise control, allowing parameter adjustments based on specific motor characteristics and load conditions, thus optimizing energy use and promoting sustainable operations (Wildi, 2006). Soft starting significantly reduces mechanical wear and tear, leading to longer operational life and decreased downtime (Rodriguez et al., 2007). This increased durability and efficiency contribute to the overall sustainability of oil mining operations by reducing equipment replacement needs and minimizing energy waste.

Recent research by Mukti et al. (2024) modeled oil extraction with a 48 kW motor power as 15 W with a 2 kg load. Their subsequent study developed an induction motor usage system for traditional oil mining, successfully designing a braking system for the

Wonocolo oil mines. This followed their earlier work replacing combustion engines with electric motors. However, field reports indicate ongoing issues, including motors failing to start or having difficulty starting, and frequent MCB tripping during startup. These challenges underscore the importance of implementing effective soft starting systems in traditional oil mining operations. By addressing the high starting currents and associated issues, such systems can significantly improve motor reliability, reduce energy consumption, and enhance the overall sustainability of oil extraction processes. The integration of affordable and robust control devices like Arduino Uno presents a promising approach to achieving these goals, particularly in remote and harsh environments typical of traditional oil fields.

## RESEARCH METHOD

The research to be conducted aims to develop a soft starting device for 3-phase induction motors. The entire research process and its implementation are described in the following flowchart:

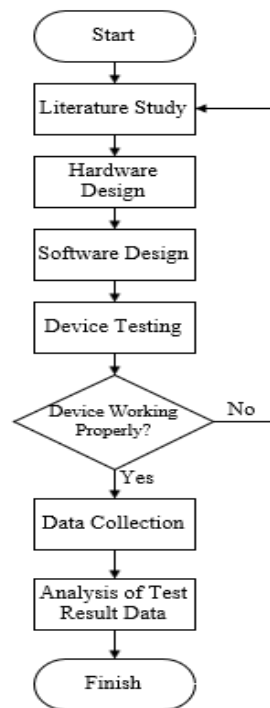

**Figure 1.** Research process flowchart

### Circuit Design

This device uses 3-phase 380 V and 5 V DC for the Arduino microcontroller, obtained by transforming one phase from 220 VAC to 5 VDC. The system includes an MCB for protection and a contactor controlled by a push button. A TRIAC, regulated by Arduino, manages the soft starting process. The Arduino receives commands via Bluetooth from an Android app through an HC-05 module. It uses a Zero Crossing Detector for AC sine wave detection and displays the ignition time on an LCD screen. The TRIAC gradually increases motor voltage, with changes monitored by an Ampere + Voltmeter. A TOR protects the motor from overload. The overall circuit can be seen in **Figure 2** below.

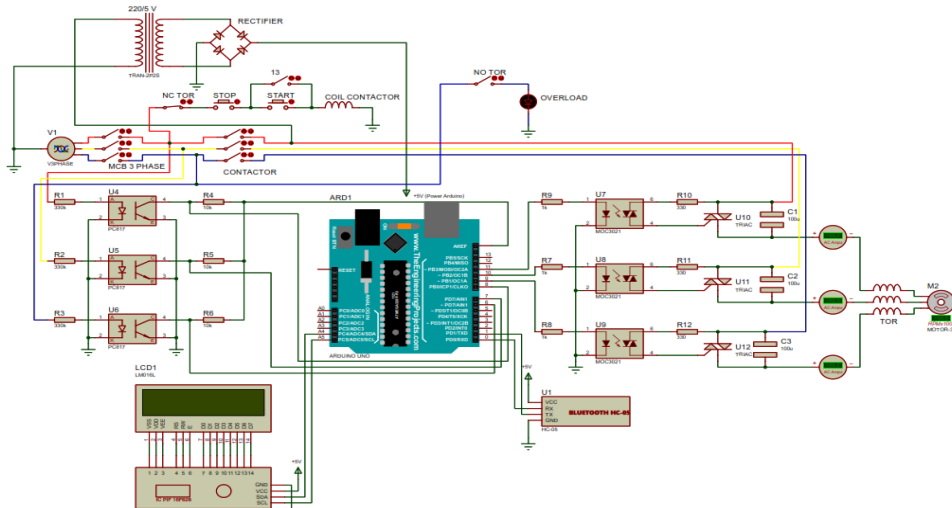

Figure 2. Overall design of the circuit

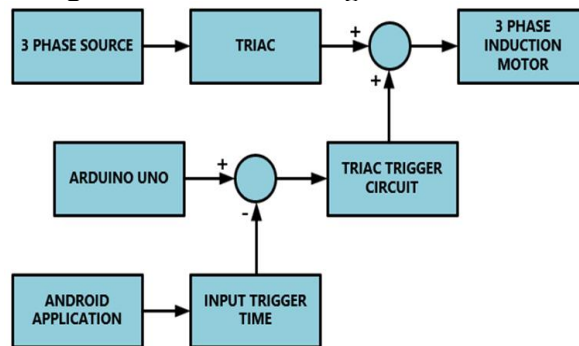

Figure 3. Block diagram of the circuit

Based on the **Figure 3**, 3-phase power source is used as a voltage source to drive the motor. The voltage entering the motor will be controlled by the TRIAC, where in order to distribute the TRIAC voltage, a trigger mechanism is required that is controlled by Arduino. In regulating the TRIAC triggering, Arduino also requires a control mechanism that is obtained through Bluetooth signal input from the Android Application. The signal input sent from the application to the Arduino is the trigger time that will be given to the TRIAC so that the TRIAC can work to regulate the ignition time.

### Data Collection

The motor that will be used in this research is a squirrel cage rotor motor type with a power capacity of 0.33 HP or 0.25 kW. When an experiment was carried out using a motor, it was found that it took 10 seconds to lift the load to the top, so it can be seen that the amount of power released by the motor to the load was 3.92 W. Then, when torque measurements were carried out, the result show that the motor connected to this load had a torque of 0.0249 Nm. Data was taken within a period of 15 seconds, with details of 10 seconds during the starting process and the next 5 seconds after the soft starting process is complete to determine if instability occurs during steady-state conditions. The load used for testing is a model of a traditional petroleum mining system. The load has a mass of 2 kg and a height of 2 m.

## RESULTS AND DISCUSSION

This section discusses the results of soft starting tests on traditional oil mining modeling.  
**Measurement Result**

After the measurement process is complete, data is obtained as in **Table 1**. The blue column is the time area where the soft starting process has been completed and the motor is rotating at its nominal voltage and speed.

**Table 1.** Soft starting measurement results

Time (s)	Voltage (V)						Current (A)			RPM	P (W)
	R-S	S-T	T-R	R-N	S-N	T-N	R	S	T		
1	0	0	0	0	0	0	0	0	0	0	0
2	70	73	132	0	11	12	0,65	0,79	0,69	1,6	33,1
3	230	240	108	85	115	111	0,81	1,14	1,03	69,2	97,3
4	231	206	260	127	127	112	1,08	1,11	1,14	668,9	132
5	161	183	227	110	105	101	1,14	1,17	1,17	796,9	113
6	172	181	149	103	98	95	1,16	1,18	1,17	1007,8	100,1
7	252	175	244	102	109	108	1,15	1,15	1,17	1298,7	132,3
8	211	212	226	153	155	156	1,19	1,16	1,15	1352,1	129
9	232	188	257	134	124	125	1,16	1,12	1,12	1439,5	130
10	391	405	393	199	233	228	0,94	0,88	0,89	1467,1	182
11	407	400	403	225	238	225	0,85	0,94	0,96	1493,9	188,9
12	399	402	399	225	221	229	0,87	0,94	0,96	1493,2	188,8
13	405	400	402	221	222	221	0,86	0,94	0,96	1493,8	189,2
14	401	408	399	228	222	222	0,86	0,94	0,96	1493,1	189,4
15	402	401	400	230	222	222	0,86	0,94	0,96	1493,4	188,6

Based on the **Table 1**, A starting current surge graph is made in **Figure 4** below.

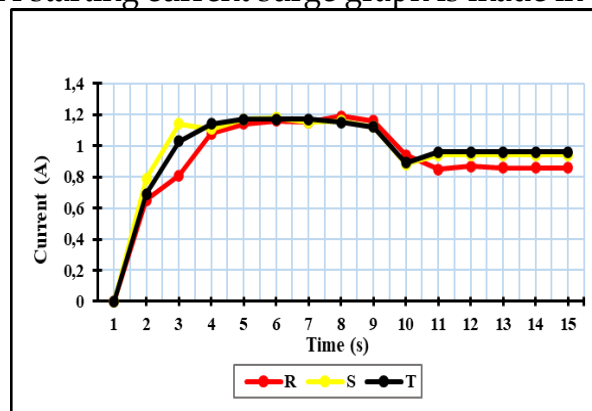

**Figure 4.** Current increase graph

### Analysis of Starting Current Characteristic

The graphic in **Figure 4** shows a gradual increase in current. The current peaks at about 150% of nominal in 4-9 seconds, then stabilizes with a slight increase due to motor load. There is a slight imbalance between phases (R, S, T), which is common in three-phase systems.

The maximum current reaches 1.2-1.3 A, much lower than the direct starting method, reducing stress on components and minimizing voltage drops. The small fluctuations in current at steady state are likely due to load characteristics or control system interaction. Similar patterns across all phases indicate good system balance and consistent soft starter performance. The current is stable after starting, indicating successful control system operation. The soft starting system handles load characteristics well, without significant current spikes.

### Comparative Analysis with DOL Starting

To validate the effectiveness of this soft starting method, a comparative analysis is needed with other starting methods, namely the Direct On-Line (DOL) method. The DOL method was chosen as a comparison because it has the largest current surge characteristics among other starting methods, so that the difference in current characteristics will be easier to observe. In DOL starting, current surges generally occur in a very short duration, especially if the motor has a relatively small power. In this motor, the duration of the current surge only occurs in 0.3 seconds as seen in **Figure 5**.

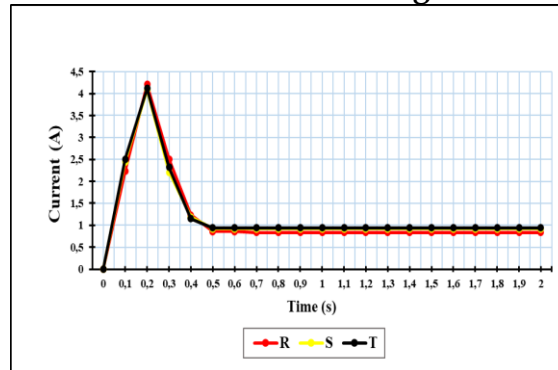

**Figure 5.** Current characteristics in DOL starting

Analysis of Figure 4 and Figure 5 shows the characteristic differences between the DOL and soft starting methods. In the DOL method, a current surge occurs up to 500% of the nominal current (about 4-4.2 A), but only lasts for a short time for 300-400 milliseconds. In contrast, soft starting produces a lower current surge, about 150% of the nominal current, but lasts longer, about 6 seconds (from the 3rd to the 9th second).

### **Impact on Reducing Energy Consumption**

The implementation of soft starting for induction motors in traditional oil mining operations demonstrates significant potential for reducing energy consumption. By controlling the starting current and voltage applied to the motor, soft starting minimizes energy waste during the motor's acceleration phase.

Our comparative analysis with DOL starting showed that the soft starting method limits the current surge to approximately 150% of the nominal current, compared to 500% in DOL starting. This significant reduction in peak current directly translates to lower energy consumption during start-up. The gradual voltage increase applied by the soft starter results in a more efficient use of energy during acceleration, contrasting with DOL starting where full voltage is applied immediately, leading to energy waste in the form of heat and mechanical stress.

### **Increased Sustainability due to Reduced Energy Consumption**

The implementation of soft starting for induction motors in traditional oil mining has a dual positive impact on industrial and environmental sustainability. From the industrial perspective, the technology improves operational efficiency and extends equipment life by reducing mechanical stress. This reduces the frequency of equipment replacement, which in turn minimizes environmental impacts related to manufacturing and disposal. From an environmental perspective, reduced energy consumption directly reduces greenhouse gas emissions and reduces stress on local ecosystems. The technology also contributes to improved air quality, water conservation, and reduced habitat disturbance around mining sites.

The precision control capabilities of Arduino-based soft starters allow for detailed motor performance data collection and analysis, which can be used for further optimization.

The adoption of this energy-efficient technology is also in line with global sustainability goals and increasingly stringent environmental regulations.

Overall, the use of soft starting creates a ripple effect of sustainability benefits that extend from the industrial sector to the wider environment, helping the oil and gas industry improve its sustainability practices.

## CONCLUSION

The developed module successfully performed the soft starting and DOL starting processes on a 3-phase induction motor quite well, although there was current imbalance and voltage fluctuation occur during its process. In the soft starting method, the current surge reached 150% of the nominal current for 6 seconds, while the DOL method produced a higher surge (500% of the nominal) but only lasted 0.3 seconds. This difference in characteristics shows the advantage of soft starting in reducing stress on the motor's electrical and mechanical systems, which has the potential to extend equipment life and reduce maintenance costs. Furthermore, the implementation of soft starting on induction motors in traditional oil mining not only significantly reduces energy consumption, but also improves the sustainability of the industry and the environment through emission reduction, resource conservation, and ecosystem protection. These dual benefits create an effective solution to improve operational efficiency while minimizing environmental impacts, thus making a positive contribution to more sustainable mining practices in the long term.

## ACKNOWLEDGEMENTS (OPTIONAL)

This work was supported by Politeknik Negeri Malang [5338/PL2.1/HK/2024]

## REFERENCES

- Sen, P. C. (2021). *Principles of Electric Machines and Power Electronics, International Adaptation*. John Wiley & Sons.
- Rashid, M. H. (2021). Power Electronics: Devices, Circuits and Applications. *TIDEE: TERI Information Digest on Energy and Environment*, 20(2), 277-277.
- J Chapman, S. (2004). *Electric Machinery Fundamentals, 5th ed.* New York, NY: McGraw-Hill Education.
- De Almeida, A. T., Ferreira, F. J., & Both, D. (2014). Technical and economical considerations in the application of variable-speed drives with electric motor systems. *IEEE Transactions on industry applications*, 41(1), 188-199.
- Margolis, M., Jepson, B., & Weldin, N. R. (2020). *Arduino cookbook: recipes to begin, expand, and enhance your projects*. O'Reilly Media.
- Wildi, T. (2006). *Electrical Machines, Drives, and Power Systems*. Pearson Educación.
- Rodriguez, J., Pontt, J., Silva, C. A., Correa, P., Lezana, P., Cortés, P., & Ammann, U. (2007). Predictive Current Control of a Voltage Source Inverter. *IEEE transactions on industrial electronics*, 54(1), 495-503.
- Mukti, H., Duanaputri, R., Ridzki, I., & Hakim, M. F. (2024). Braking System for a 3-phase Induction Motor in Traditional Petroleum Mining. *International Journal of Electrical Engineering and Applied Sciences (IJEEAS)*, 7(1).